

Wire-In Photoelectric Controls

FT Series / SFT Series



FT Series



SFT Series

The FT Series photoelectric control is enclosed in a UV-resistant rain tight polycarbonate housing with a 1/2" threaded nipple. All controls are factory calibrated to a 1.0 footcandle (fc) turn-on. The shutter allows field adjustment of turn-on.

The SFT Series photoelectric control incorporates a swivel mounting for positioning flexibility. All other design features and ratings are identical to the FT Series control described above.

Application

The FT/SFT Series spec-grade, conduit-mounted controls are designed for safety and security lighting of walkways, entrances, parking lots, farm yards, recreational and public areas. These highly reliable controls are ideal for protective lighting in schools, malls, commercial and industrial buildings. To ensure proper operation, the SFT swivel unit permits adjustment away from highly lit areas where the control might 'see' light from adjacent fixtures.

FT/SFT Series Wiring Diagram

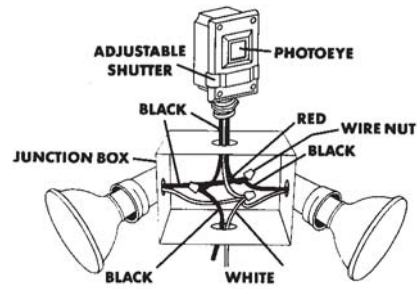

Specifications

- Photocell:** Cadmium sulfide (CdS)
- Switch Type:** SPST-NC (single-pole, single-throw, normally closed) bimetallic switch.
- Nipple:** 1/2" - 14 thread; 5/8" long; fits 1/2" knockout.
- Leads:** 15" long; color coded; 105 C wire, 1/2" stripped.
- Turn-On:** 1 to 5 footcandles (fc). Field adjustable using the sliding shutter.
- Turn-Off:** 3 to 15 footcandles (fc).
- Time Delay:** 30 seconds minimum.
- Rated Life:** 5,000 operations minimum at rated load.
- Temperature Range:** - 40° to + 60°C
- 40° to +140°F
- Dimensions:**
FT Series: 3.60" L; 2.05" W; 1.4" D
SFT Series: 6.00" L; 2.05" W; 1.4" D

FT Series Mechanical Diagram

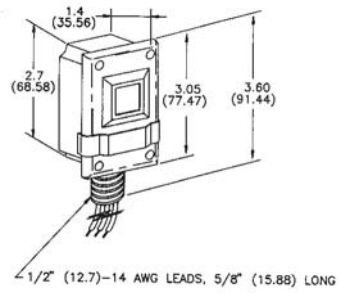

SFT Series Mechanical Diagram

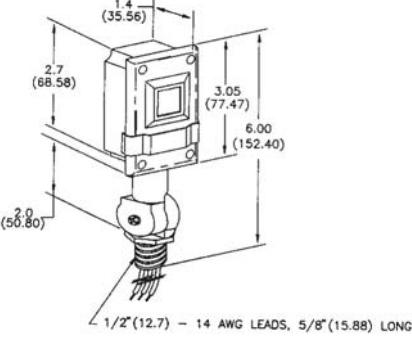

Ordering Information

Model	Line Voltage	Load Rating	
		Tungsten	HID Ballast
FPFT15	120	2000W	1000VA
FPFT168	208-277	2000W	1000VA
FPSFT15	120	2000W	1000VA
FPSFT168	208-277	2000W	1000VA
*FPFT19	480	2000W	1000VA
*FPSFT19	480	2000W	1000VA
*FPFT305	105-305	1000W	1800VA
*FPSFT305	105-305	1000W	1800VA
**FPAT30	120	2000W	1000VA

*Not UL/CSA certified
**Diecast - not UL/CSA certified